

## COLUMN ASSEMBLY AND INSTALLATION

### COLUMN TYPE: RAISE & LOWER SPRING - FLANGEPLATE MOUNTED

**WE STRONGLY RECOMMEND THAT THESE INSTRUCTIONS ARE READ CAREFULLY BEFORE ATTEMPTING TO INSTALL AND OPERATE THIS EQUIPMENT.**

**REFERENCE SHOULD ALSO BE MADE TO THE APPROPRIATE COUNTERBALANCE OPERATING INSTRUCTIONS WHICH ARE SUPPLIED WITH THE UNIT.**

### GENERAL

These columns have a wide variety of uses including amenity, railway and road lighting applications up to 8m in height, either post top or with a projection bracket.

Assembly on site is kept to a minimum. Ideally the foundation bolts should be cast in to the concrete foundation 3 to 4 weeks prior to erection of the column to allow time to cure. Foundation block sizes for a variety of ground conditions can be supplied on request.

Columns are constructed from lengths of steel tube, to EN10210 grade S275 or S355, welded together to form the required mounting height. The column and foundation bolts are finished galvanised with small fasteners from stainless steel.

### INSTALLATION

**Reference should be made to the illustrations which follow the text.**

**NOTE: IT IS NOT POSSIBLE TO ATTACH A SPRING COUNTERBALANCE TO A COLUMN WHICH HAS BEEN INSTALLED WITH ITS SHAFT IN THE LOWERED POSITION. WE WOULD STRONGLY ADVISE THAT SUCH COLUMNS ARE INSTALLED IN THE SAME MANNER AS A CONVENTIONAL COLUMN.**

- i) Before commencement of installation examine the items and ensure that there are no missing or damaged parts. The following items of equipment will be required (not Abacus supply). Timber supports and packers, a mobile crane for erection, typically 1.0 tonne and a torque multiplier and wrench.
- ii) Assemble the bracket to the top shaft section and secure with the screws provided. It should be noted that the power supply cable can be installed during assembly or, if preferred after assembly is completed, but prior to fixing the bracket.
- iii) While the column is on the ground, and referring to the counterbalance operating instructions, ensure that the column is in its locked position and that the locking device is in place.
- iv) The holding down bolts are each fitted with two nuts and washers. The upper nut and washer and template should be removed. The threads should be examined for any damage and rectified using a die nut if necessary. The nuts should be set in level plane using a steel bar and spirit level across each opposing pair of nuts.
- v) Using a crane lift the column and place carefully over the foundation bolts and on to the lower set of nuts. Ensure the direction of lowering is as required and that the column will clear any obstructions. Secure the column with the upper set of retaining nuts and washers and roughly plumb up the base section.

**INSTALLATION**

vi) After completion of the installation check for vertical alignment. This can be adjusted using the upper and lower nuts as necessary. Once the alignment is satisfactory all bolts should be tightened to the required torque setting.

If the gap below the flange is to be grouted it is essential that adequate provision is made for ventilation and drainage of any water collecting inside the base.

vii) The column can then be commissioned.

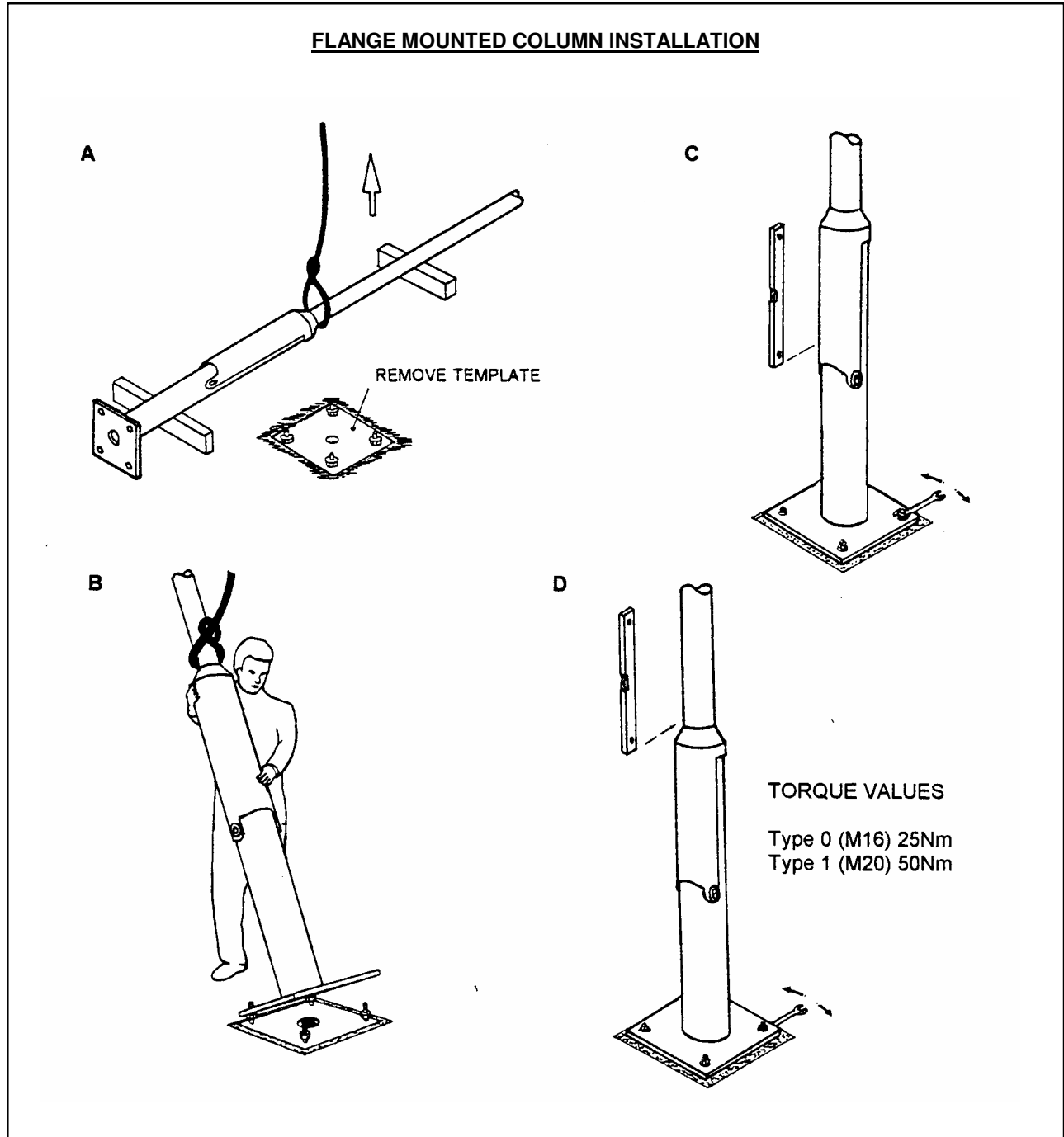

**FOR FURTHER ADVICE CONTACT THE ABACUS TECHNICAL DEPARTMENT**

UK and World-wide Patents

ABACUS LIGHTING LIMITED. Sutton - in - Ashfield, Nottinghamshire, NG17 5FT, England. Tel: (+44) 01623 51111 Fax: (+44) 01623 552133

## COLUMN ASSEMBLY AND INSTALLATION

### COLUMN REF: RAISE & LOWER - Ø168RLS & Ø168RLH (CAM TYPE)

**WE STRONGLY RECOMMEND THAT THIS CLEARANCE ZONE INFORMATION IS READ IN CONJUNCTION WITH THE INSTRUCTIONS FOR COLUMN ASSEMBLY, INSTALLATION AND COUNTERBALANCE OPERATION.**

#### GENERAL

It is essential that the area around the base is kept clear of obstructions at all times to allow for the safe operation of mast and counterbalance. The illustration below gives details of the minimum clearance zone that is required around the column.

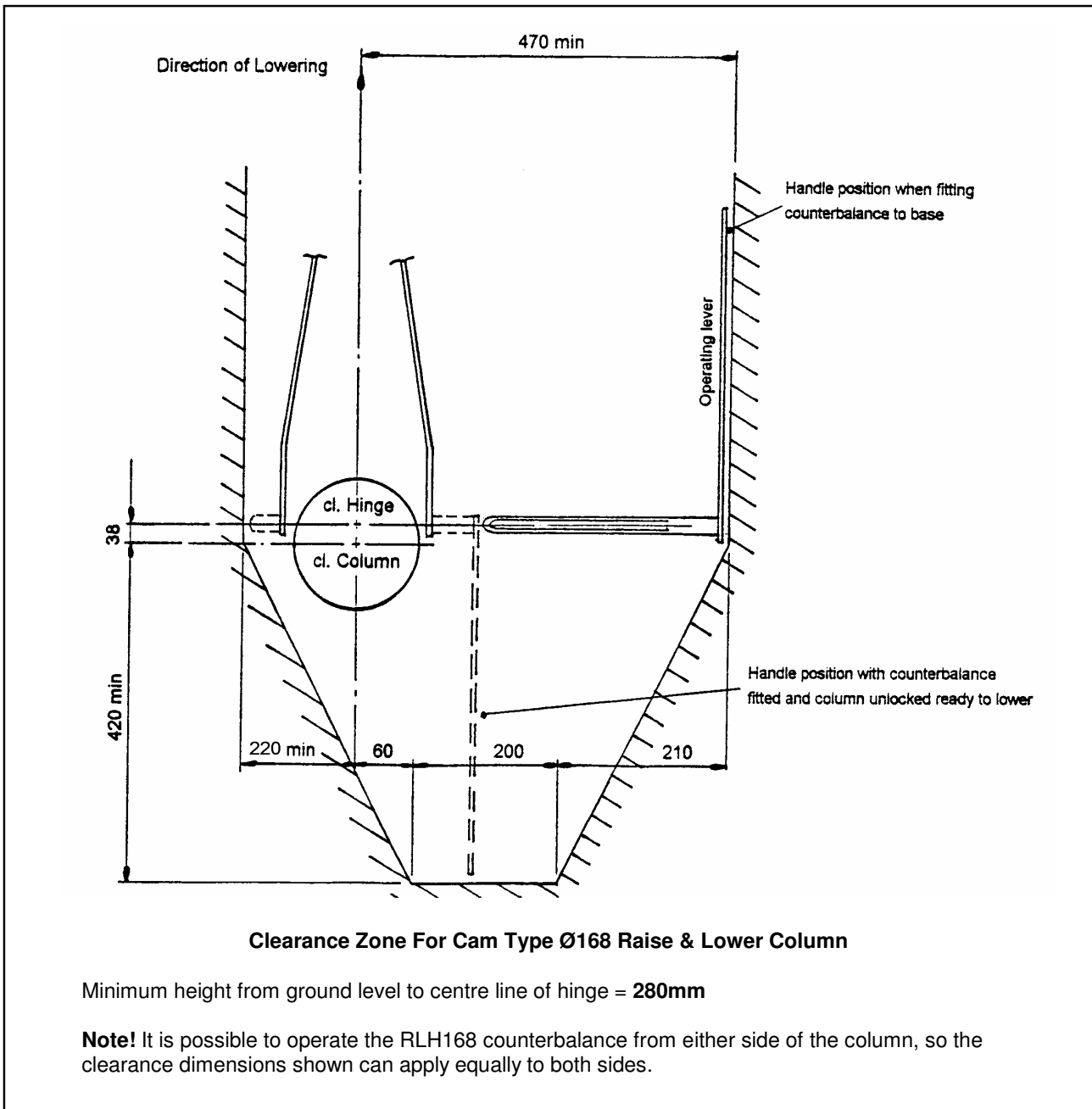

## COLUMN ROUTINE MAINTENANCE

### COLUMN TYPE: RAISE & LOWER SPRING Ø168 BASE

**WE STRONGLY RECOMMEND THAT THESE INSTRUCTIONS ARE READ CAREFULLY BEFORE ATTEMPTING ANY MAINTENANCE ON THIS EQUIPMENT.**

These columns are of galvanised steel construction with tubular base and shafts and require minimal maintenance. The following checks should however be made at the intervals stated.

#### EVERY TIME THE COLUMN IS LOWERED

1. Check that all the hinge components are present and undamaged before lowering the column.
2. Check that the flexible conduit is not damaged.
3. Examine the operating lever for damage.

#### EVERY 12 MONTHS

1. Check that all hinge components are present and undamaged.
2. Check that the column locking screw is present and fitted correctly. Lightly grease the threads.
3. If the column is flange mounted check that the foundation bolts have not worked loose. The torque settings are as follows:-  
**M16 = 25Nm**  
**M20 = 50Nm**
4. Check the warning label is attached to the base.
5. Check that the minimum distance from pivot centre to ground level of **280mm** has not become obstructed, making counterbalance operation difficult.

#### MAJOR MAINTENANCE AT 15 YEARS

1. Conduct a detailed examination of all critical areas on the mast.
2. Repair and replace components as necessary.
3. Carry out non destructive test on foundation bolts if applicable.

#### AS REQUIRED

1. Paint the shafts and base. Aesthetically the galvanised finish will typically last 5 - 7 years before painting is required. In polluted or saline environments this may be shorter and in a mild climate considerable longer.

**Lubrication of the cam unit is not recommended.**

