

TIBER AL5120



Benefits

- Value flat glass floodlight offering high performance 50° reflector
- 50° high grade performance reflector to give highly efficient light output
- Flat glass therefore dark skies friendly
- Sealed to IP65 and coated in all-weather and corrosion resistant polyester powder
- Three reflector options to adapt to wide range of applications
- Access to lamp and gear by loosening two screws and sliding top clamp bar for quick and simple servicing
- Wide cooling fins incorporated in the body dissipate heat effectively

- Heat resistant silicon gasket sealed
- Galvanised steel stirrup with M12 central bolt hole
- With integral gear
- 150W, 250W and 400W options
- Choice of high pressure sodium or metal halide lamps
- Protection grid accessory available

Accessories

- Protection grid

Colours

- RAL9005 Black



Technical Features

- Body in die cast aluminium and polyester powder coated
- Thermal separation between lamp and wiring box
- 4mm tempered glass
- Double asymmetric 50° and asymmetric reflector option

	Lamp Watts	Lamp Type	Lamp Holder	Description	Weight (Kg)
AL5121	150W	SONP-T / HQI-T	E40	Narrow Symmetric Beam Integral Control Gear	9.79
	250W				10.32
	400W				11.51
AL5122	150W	SONP-T / HQI-T	E40	Asymmetric Beam Integral Control Gear	9.79
	250W				10.32
	400W				11.51
AL5123	150W	SONP-T / HQI-T	E40	Double Asymmetric (50°) Beam Integral Control Gear	9.79
	250W				10.32
	400W				11.51



Accessories



50° flat glass reflector dark skies friendly

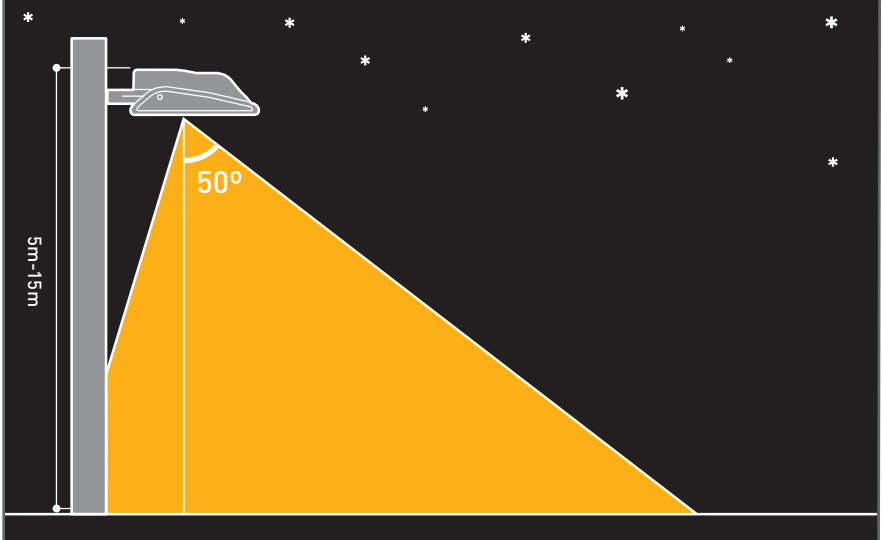

Dimensions

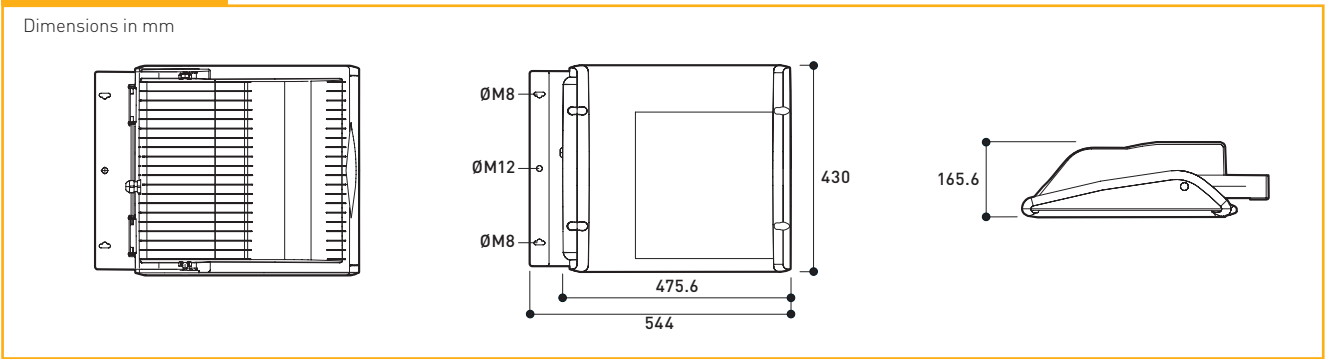

Key features

1.

AL5121
400w-SONP-T
Symmetric

2.

AL5122
400w-SONP-T
Asymmetric

3.

AL5123
400w-SONP-T
Double Asymmetric